

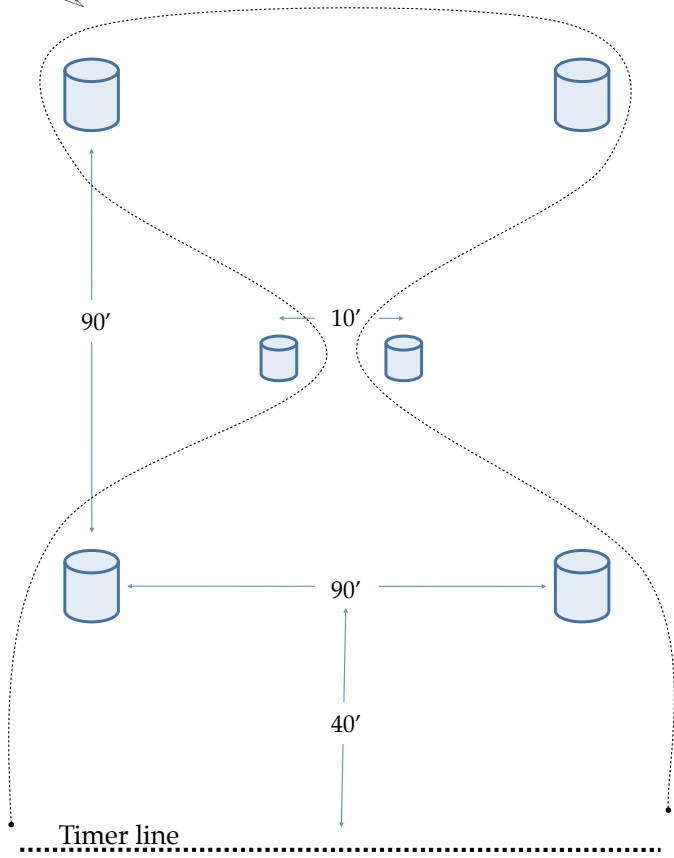

Hour Glass

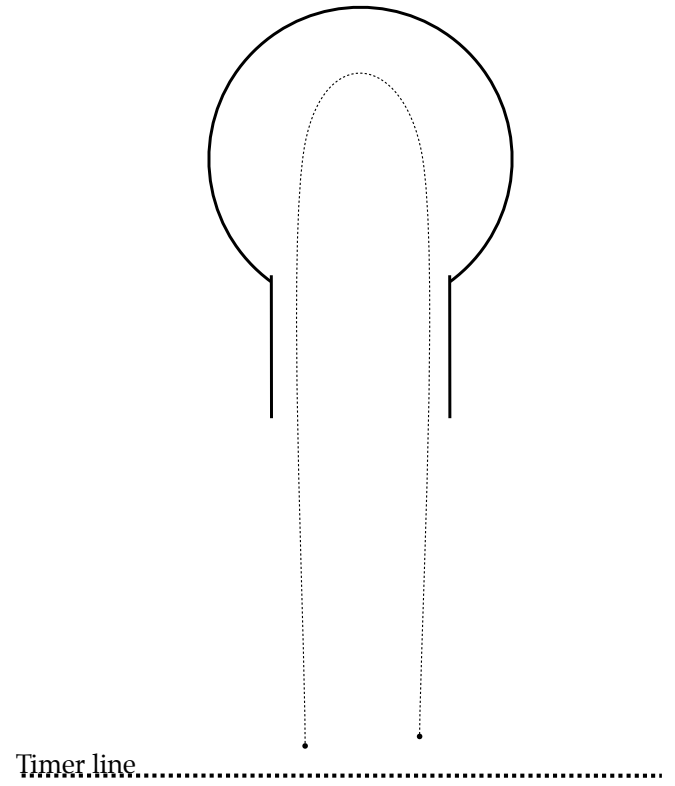

Keyhole



Cloverleaf Barrels

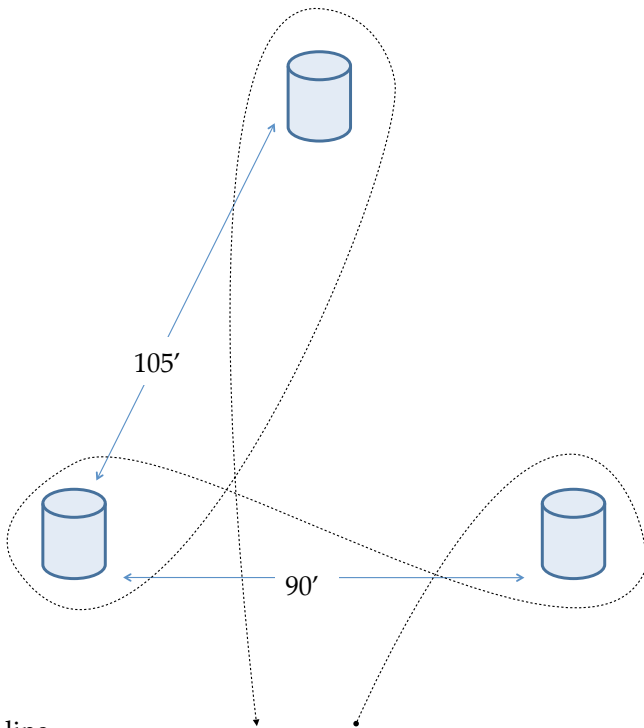

Peppermint Twist

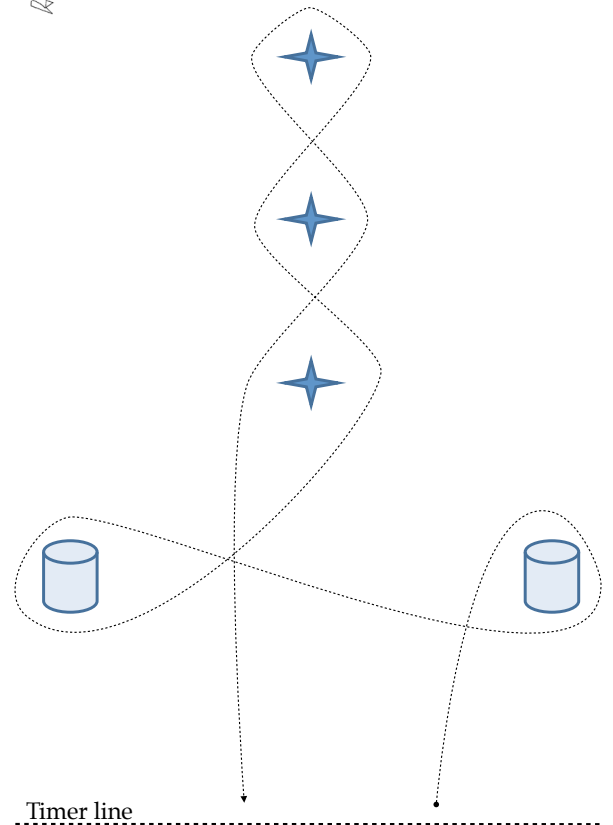

= Pole



= Barrel

= Barrel



Wild Lark

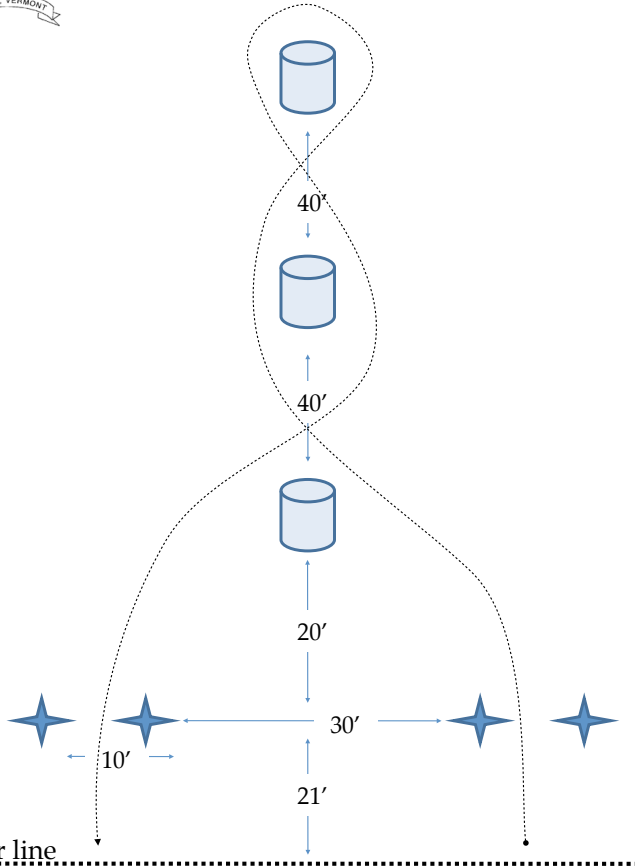

★ = Pole 🗄 = Barrel



2 Jump Cowhorse

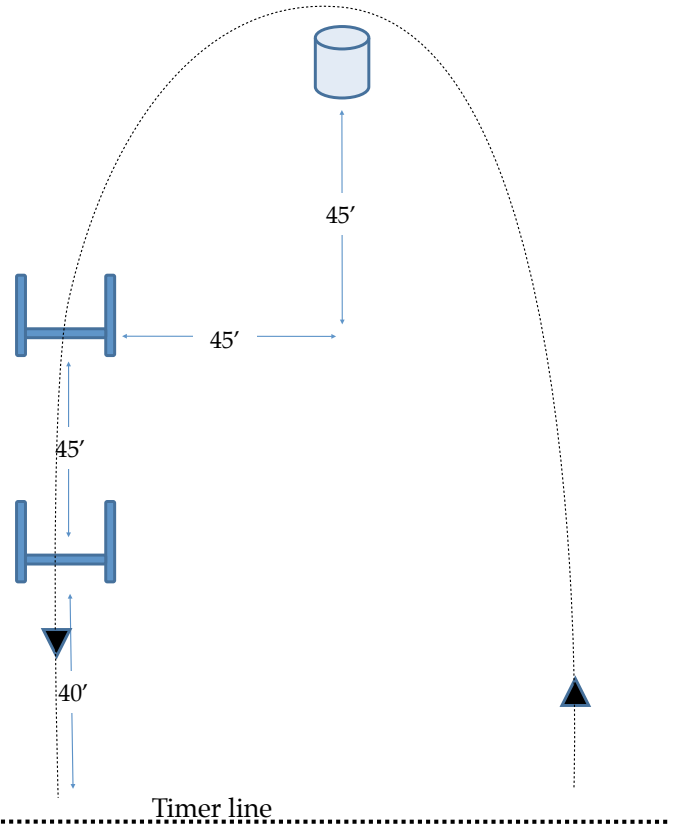

🏊 = Jump 8"-12" 🗄 = Barrel



Speed Ball

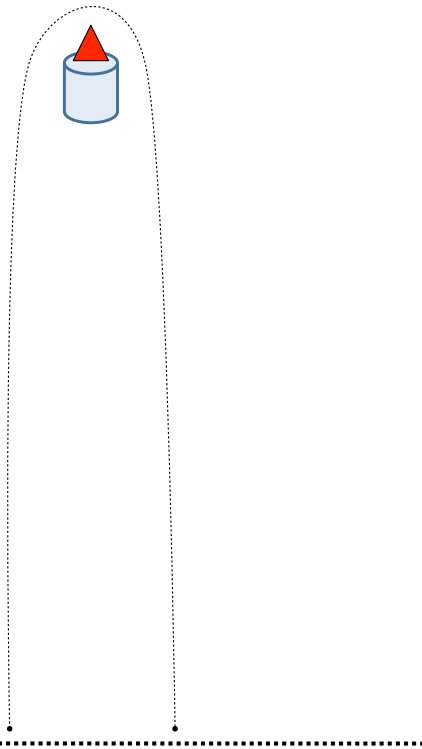

▲ = Cone 🗄 = Barrel



Bunny Barrels/Chaos

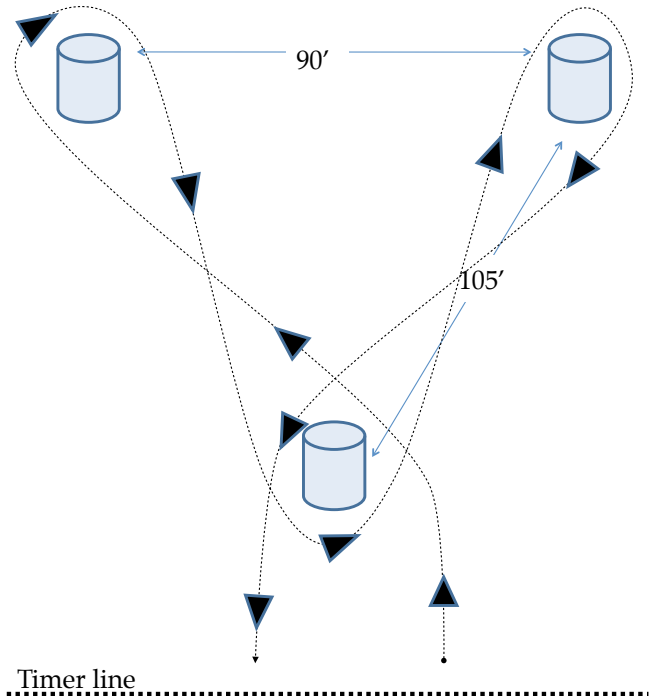

🗄 = Barrel



Thread the Needle

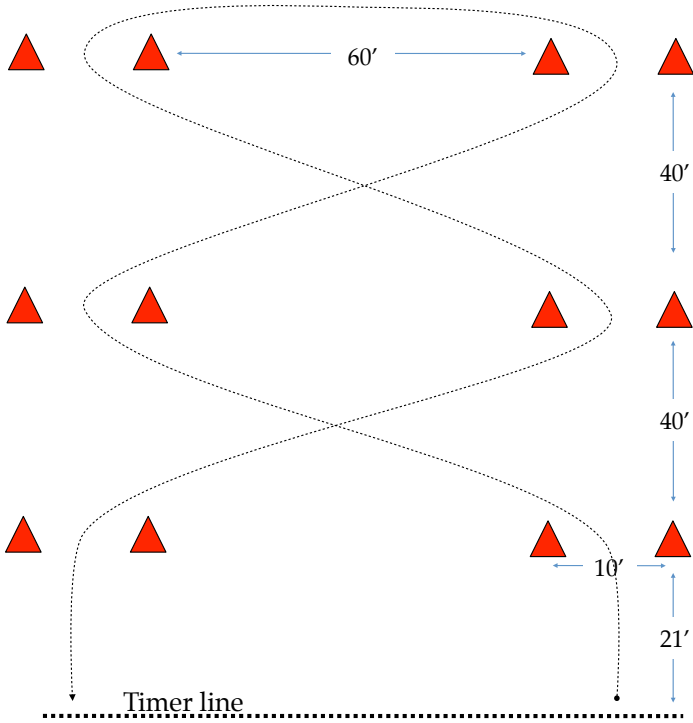

▲ = Cone



Twisted Keyhole

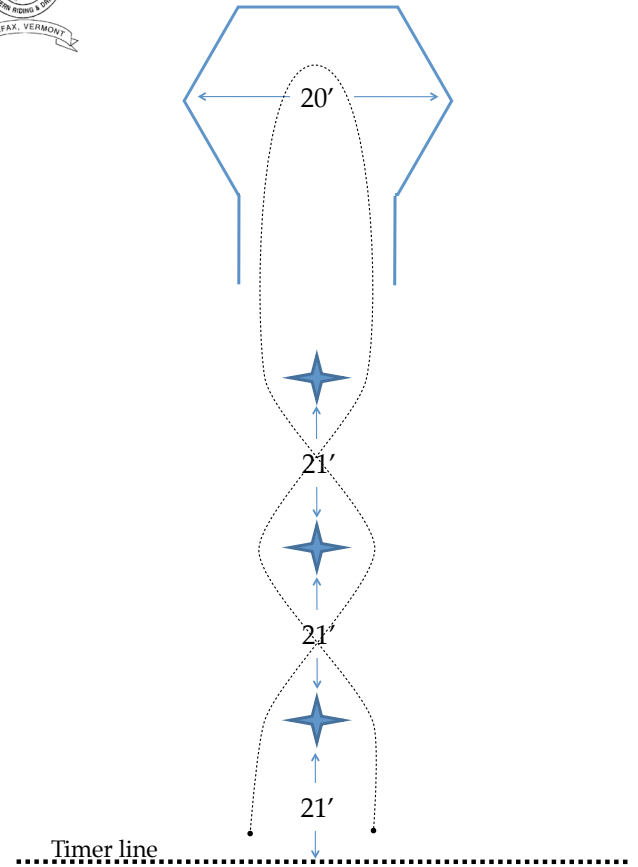

★ = Pole

— = Rail



Spur Race

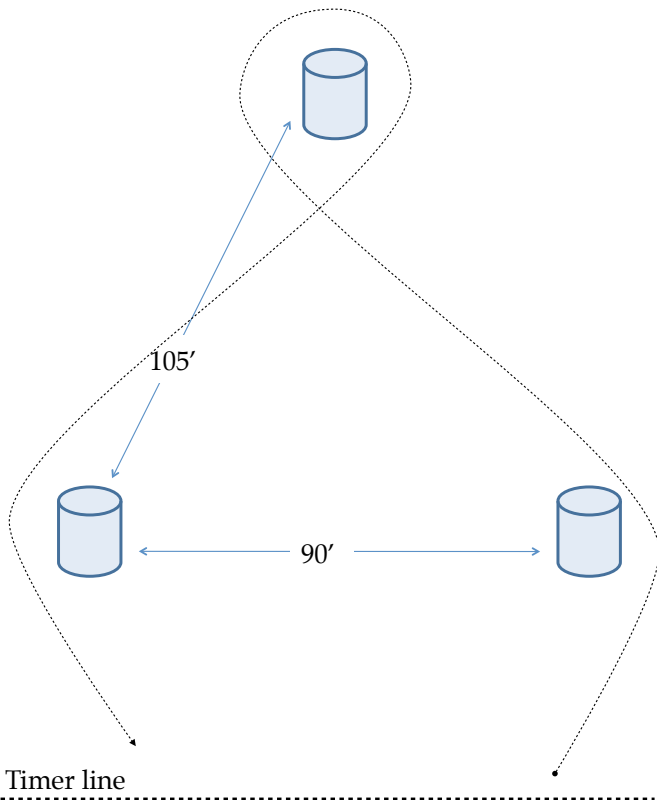

☺ = Barrel



Scramble

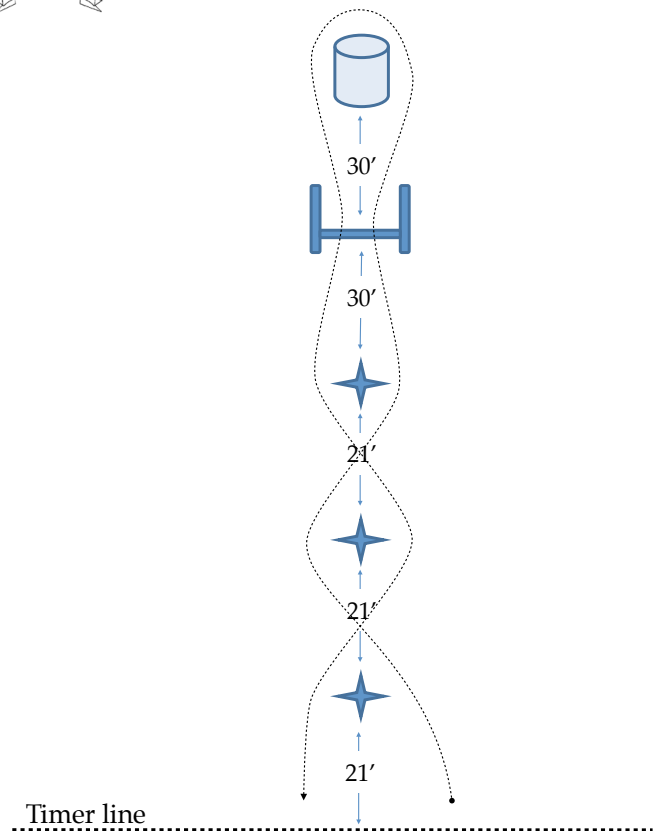

★ = Pole

⊔ = Jump 8'-12'

☺ = Barrel



Flag Race (3 barrel)

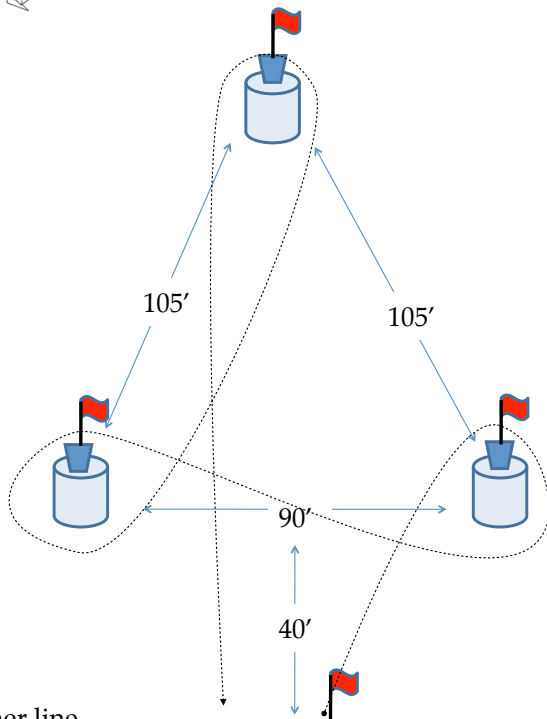

Timer line

Rider is given a flag at the gate. Object is to run a barrel pattern switching the flag at each barrel. Return to finish with a flag.



Pole Bending

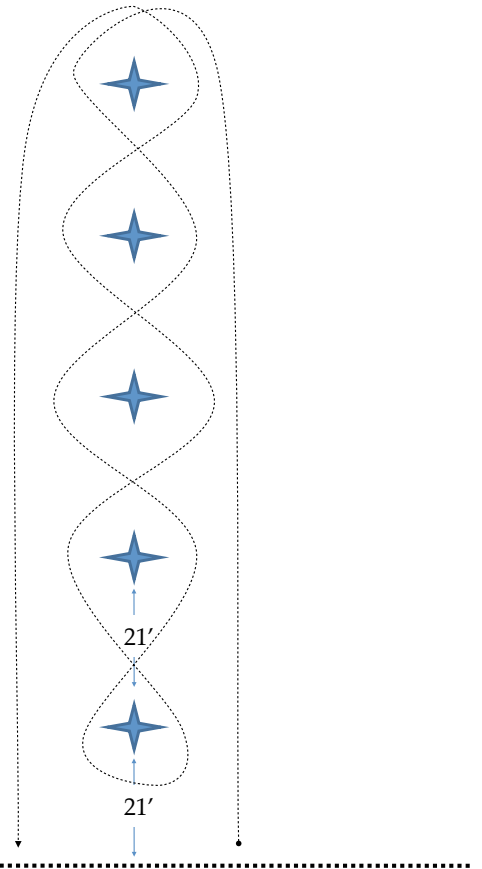

Timer line



Flag & Back

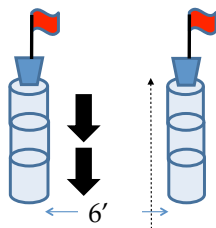

Timer line

Run in between barrels, pick up flag, back out, turn and back to the timer line.

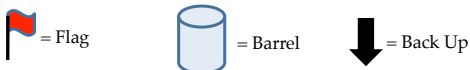

Cupid's Arrow

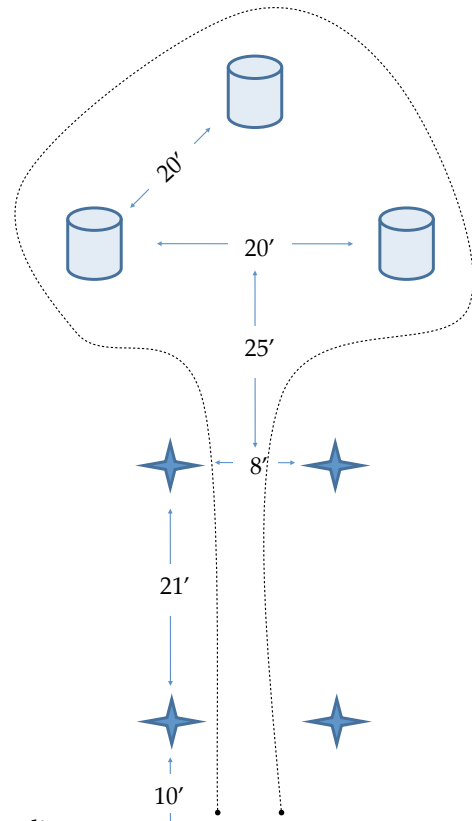

Timer line





Arizona Keyhole

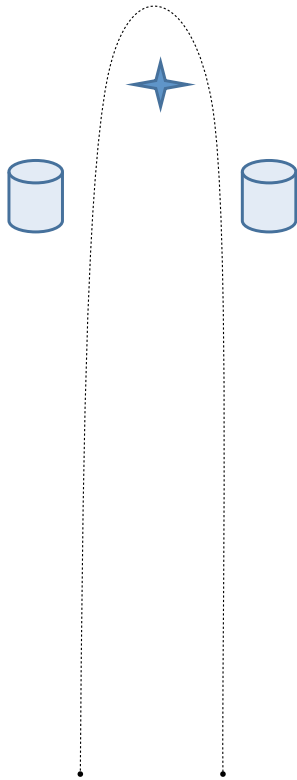

Timer line



Big O

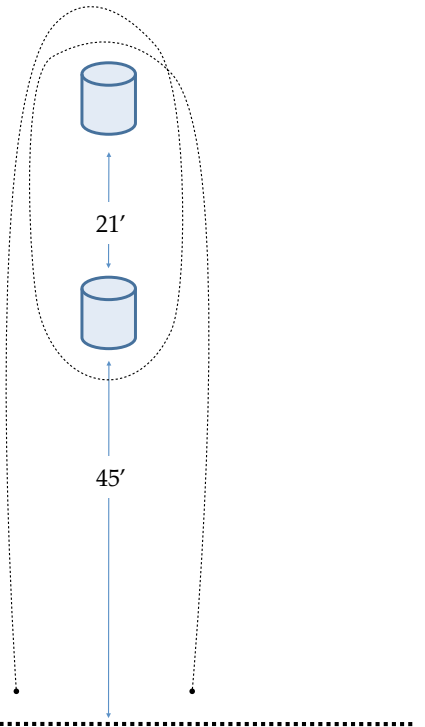

Timer line

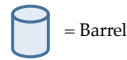

Speed Barrels

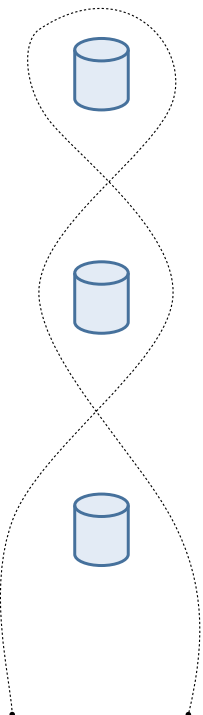

Timer line



Mountain Cow-horse

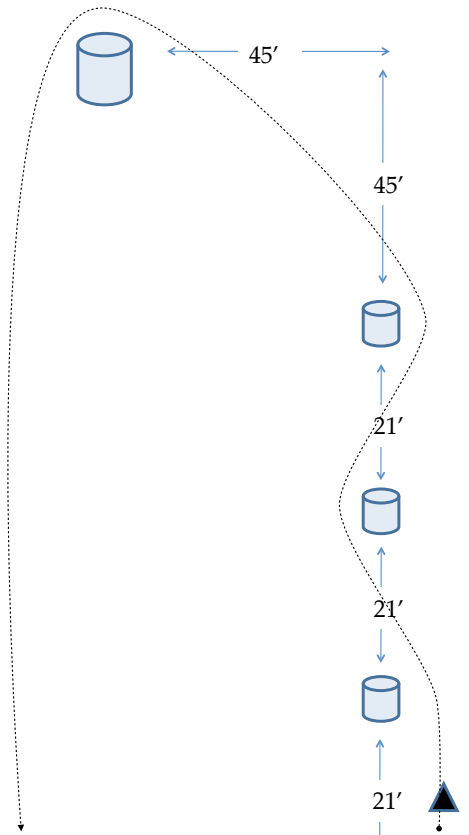

Timer line

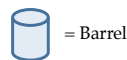



Speed Barrel

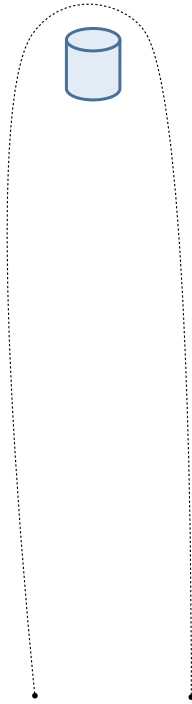

Timer line



Extreme M

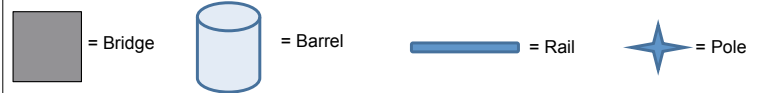
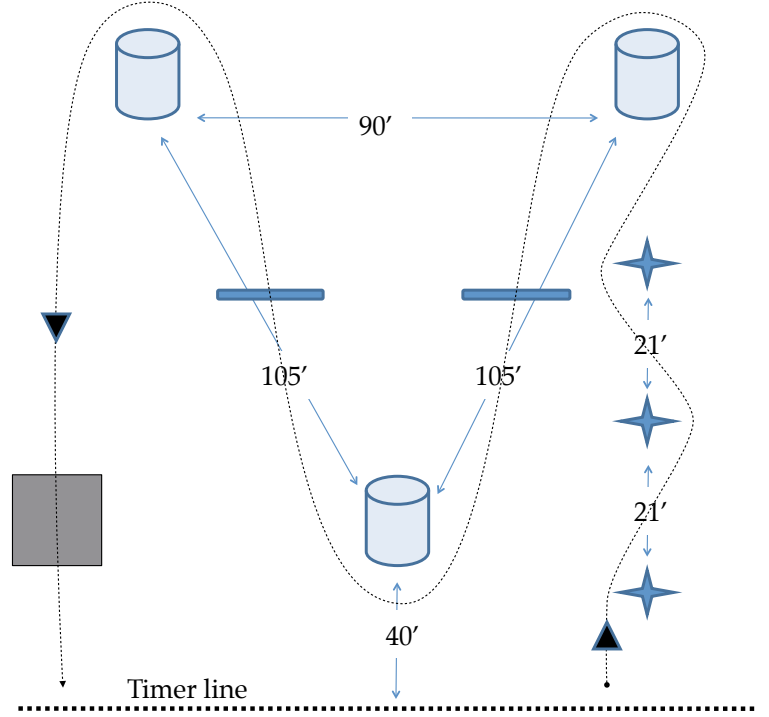

Tunnel Vision

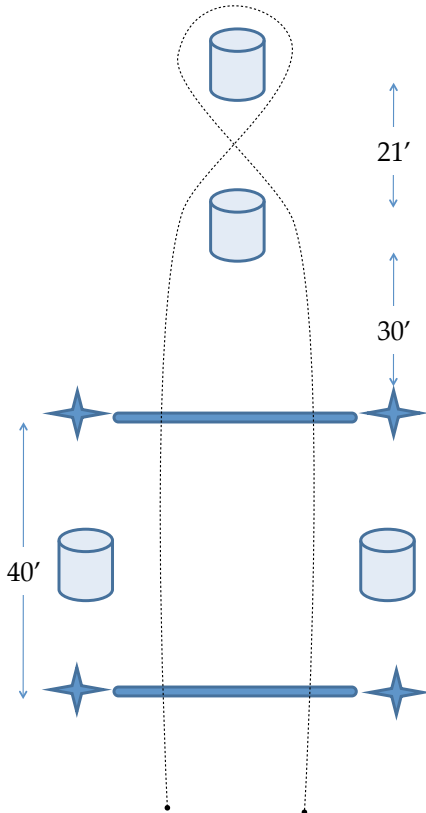

Timer line



Streaking Poles

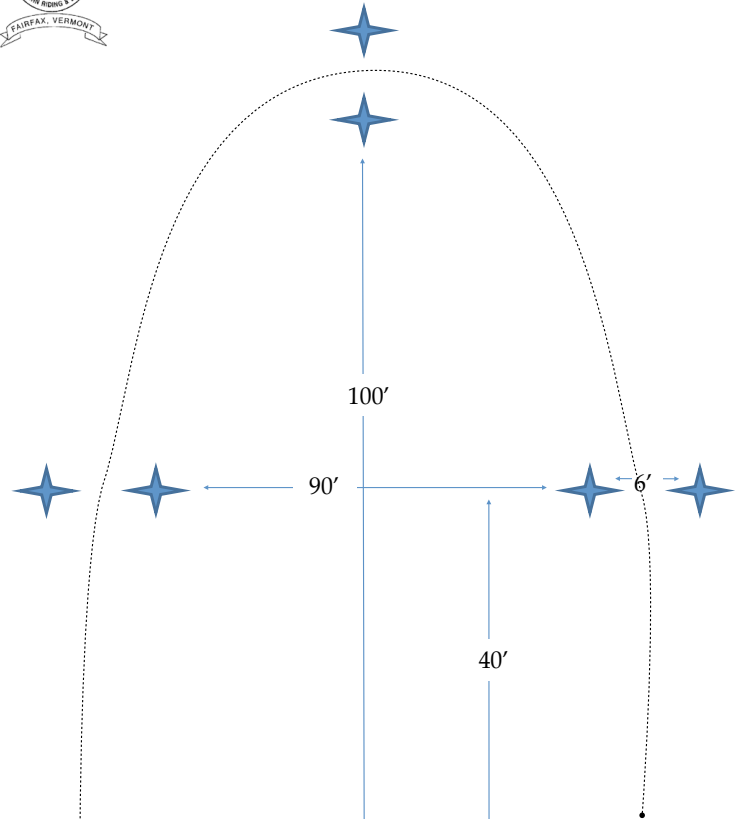

Timer line





Bootlace

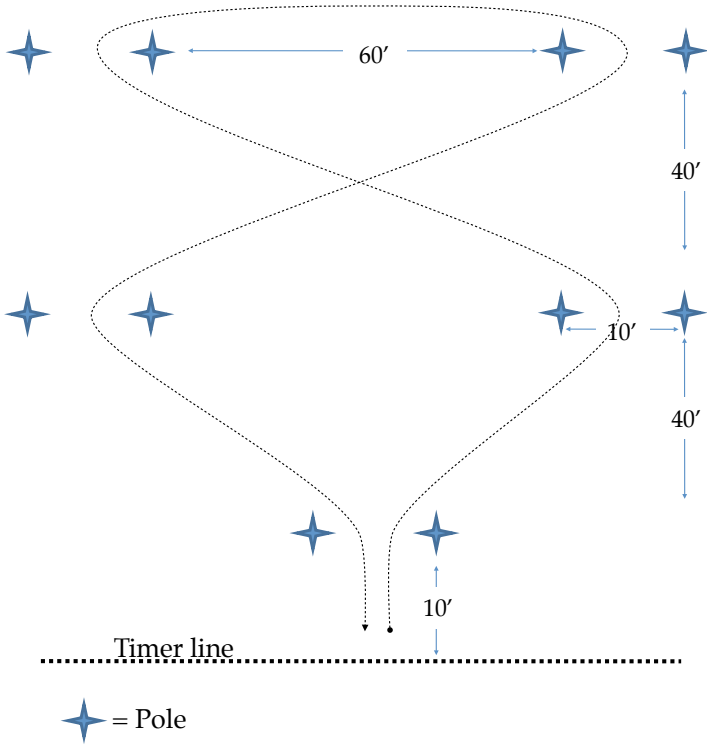

Tunnel Race

